

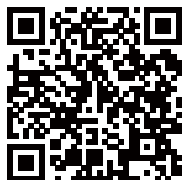

(de) Aufbauanleitung (en) Assembly Instruction (fr) Instructions de montage

(it) Istruzioni di assemblaggio (es) Instrucciones de montaje

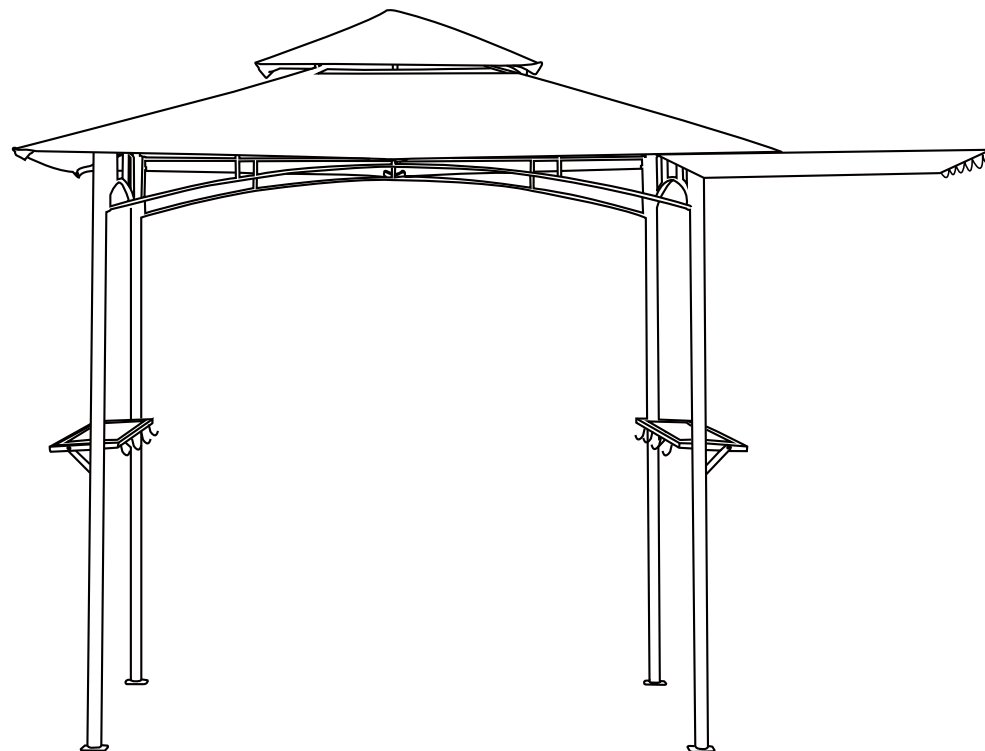

**Salcar GmbH**

**Address:** An der Hebemärchte 6, 04316 Leipzig, Germany

**E-Mail:** info@salcar.de

**Tel:** 0341 25257850

**Web:** www.sekeyoutdoor.com

**Sekey Group Corporation**

**Address:** 2 E VALLEY BLVD APT 280, ALHAMBRA, CA 91801

**Email:** info@sekeygroup.com

**Web:** www.sekeyoutdoor.com

















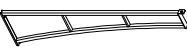

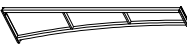













Achtung!Unbedingt zuerst lesen! Zum späteren Nachlesen aufbewahren!

Important!Read before assembling!Retain for future reference!

Attention! A lire avant l'utilisation! A conserver pour toute consultation ultérieure!

Attenzione! Leggi prima di assemblare!Conserva per futuro riferimento!

¡Atención! ¡Leala por favor antes de ensamblar! ¡Consérvela como consulta futura!

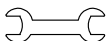
A		2	R		2
B		2	S		4
C		4	T		4
D		2	U		1
E		2	V		1
F		2	W		2
G		2	X		2
H		4	1#		30
I		4	2#		8
J		1	3#		8
K		6	4#		4
L		4	5#		2
M		2	6#		8
N		2	7#		2
O		2	8#		8
P		2	9#		1
Q		2	10#		1

2

①

Montieren Sie den Pavillonbalken (de)

Assemble the beam of gazebo (en)

Assembler le faisceau de Tonnelle (fr)

Monta il raggio del gazebo (it)

Montar la viga del mirador (es)

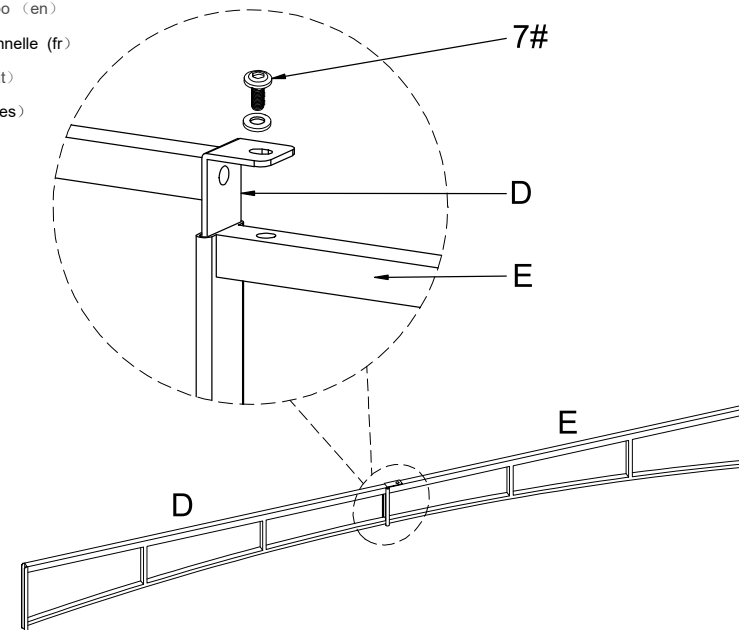

②

Montieren Sie den Pavillonbalken (de)

Assemble the beam of gazebo (en)

Assembler le faisceau de Tonnelle (fr)

Monta il raggio del gazebo (it)

Montar la viga del mirador (es)

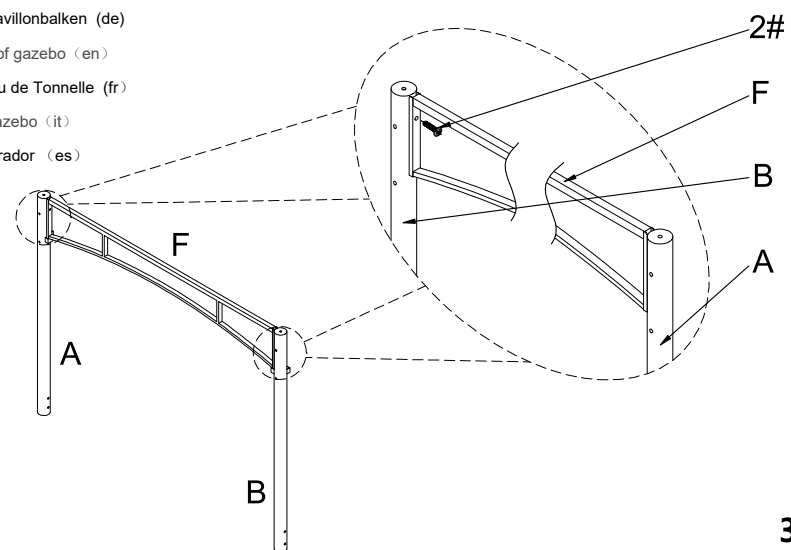

3

3

Montaje de la estructura principal (de)  
Main frame assembly (en)  
Ensemble cadre principal (fr)  
Assemblaggio del telaio (it)  
Hauptrahmen-Montage (es)

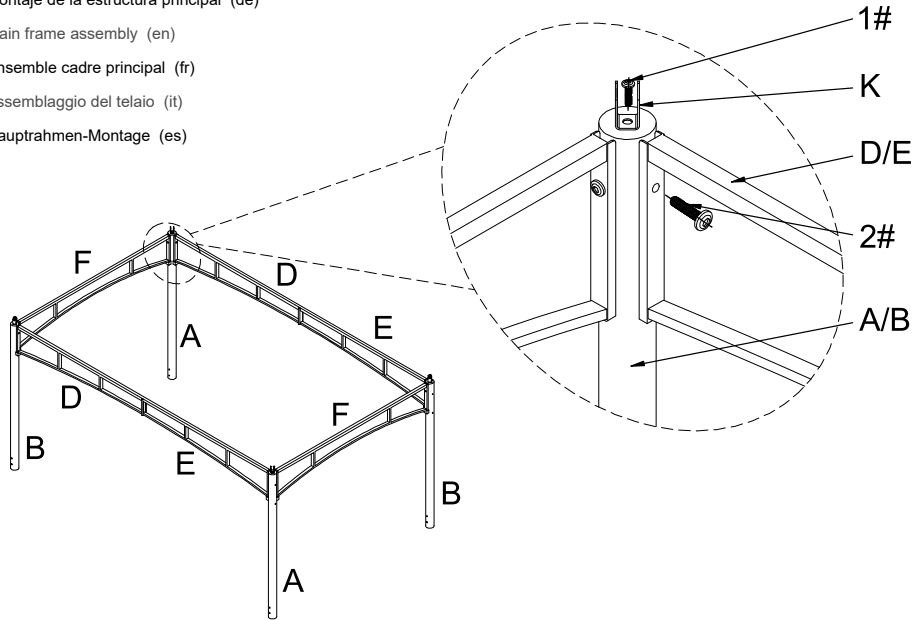

5

Der Zweite Baldachin-Rahmen Montage (de)  
The double canopy frame assembly (en)  
Assembler le deuxième auvent (fr)  
Assemblare la seconda vela (it)  
Montar el segundo toldo (es)

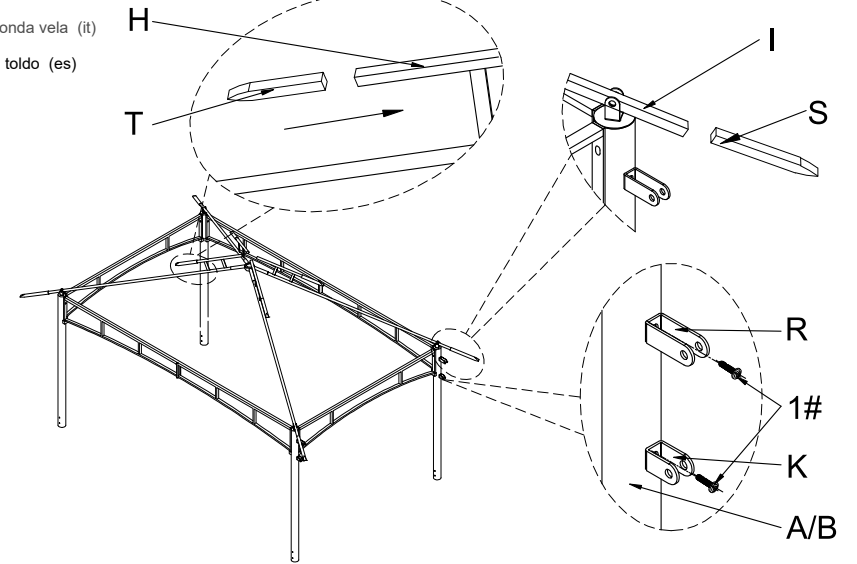

4

Baldachin-Rahmen Montage (de)  
Canopy frame assembly (en)  
Ensemble de cadre Canopée (fr)  
Assemblaggio del telaio (it)  
Montaje de la estructura superior para el toldo (es)

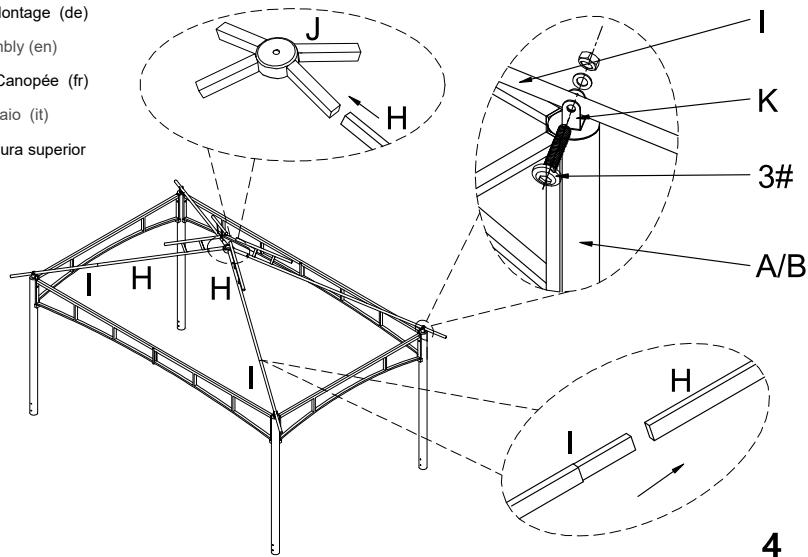

4

6

Befestigen Sie den Verdeckrahmen am Hauptrahmen (de)  
Secure canopy frame to the main frame (en)  
Fixer le cadre de protection au cadre principal (fr)  
Fissare il telaio del tettuccio al telaio principale (it)  
Asegure el marco del dosel al marco principal (es)

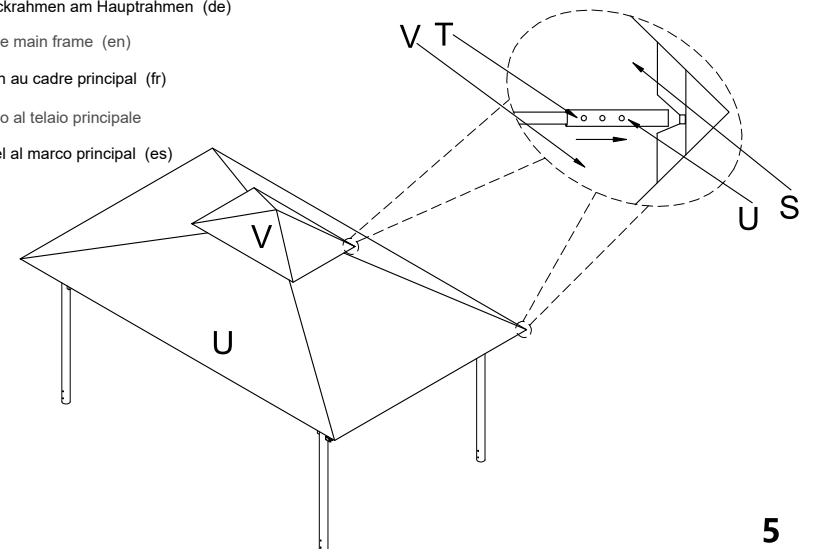

5

7

Vordach Montage (de)  
Canopy awning assembly (en)  
Ensemble d'auvent (fr)  
Assemblaggio del tende da sole (it)  
Montaje de toldos (es)

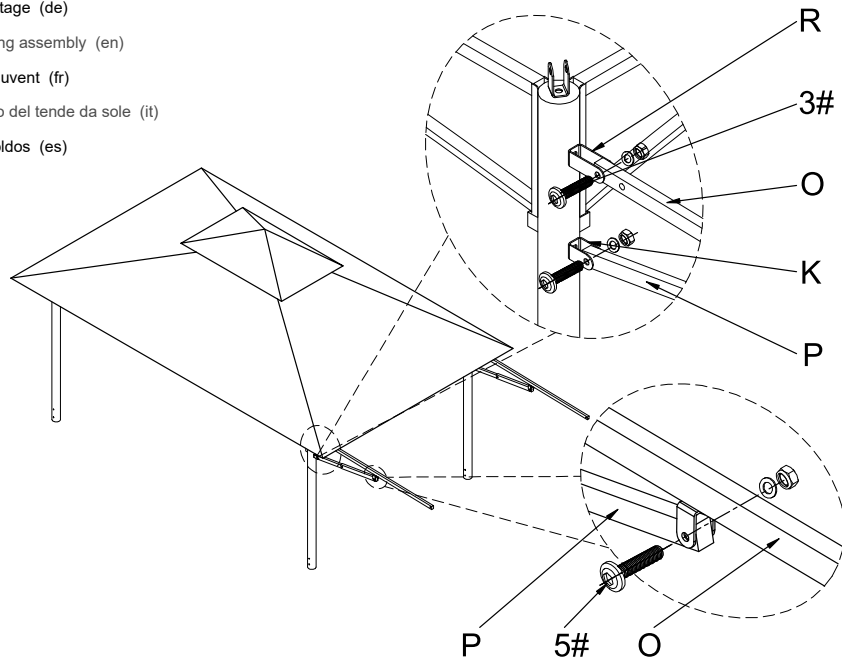

9

Vordach Montage (de)  
Canopy awning assembly (en)  
Ensemble d'auvent (fr)  
Assemblaggio del tende da sole (it)  
Montaje de toldos (es)

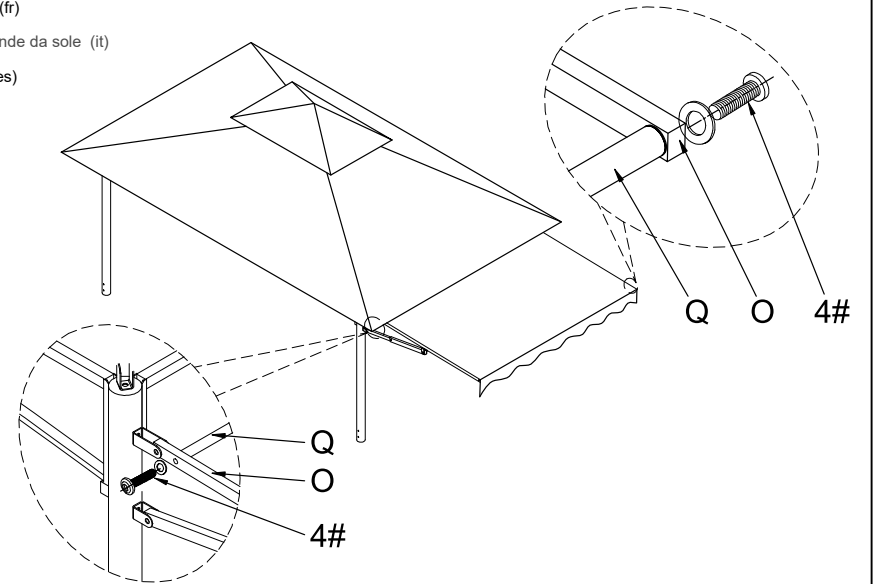

8

Vordach Montage (de)  
Canopy awning assembly (en)  
Ensemble d'auvent (fr)  
Assemblaggio del tende da sole (it)  
Montaje de toldos (es)

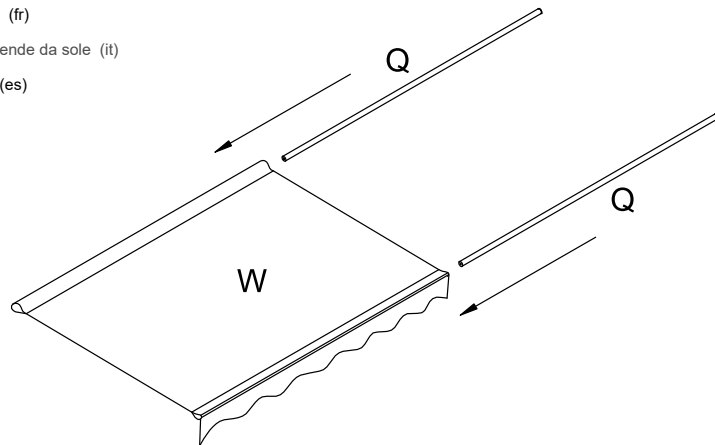

6

10

Vordach Montage (de)  
Canopy awning assembly (en)  
Ensemble d'auvent (fr)  
Assemblaggio del tende da sole (it)  
Montaje de toldos (es)

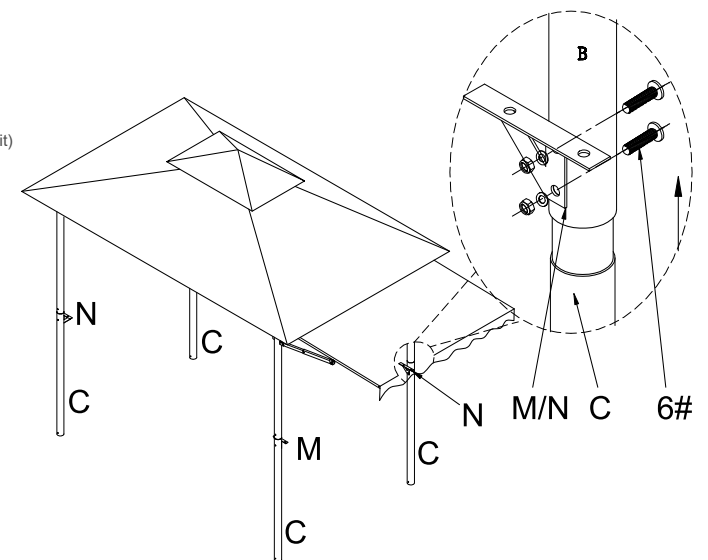

7

**11**

Befestigen Sie die Seitlichen Ablagebretter am Hauptrahmen (de)

Attach side shelves to the main frame (en)

Fixez les étagères latérales au cadre principal (fr)

Collegare i ripiani laterali al telaio principale (it)

Coloque y fije los estantes laterales a la estructura principal (es)

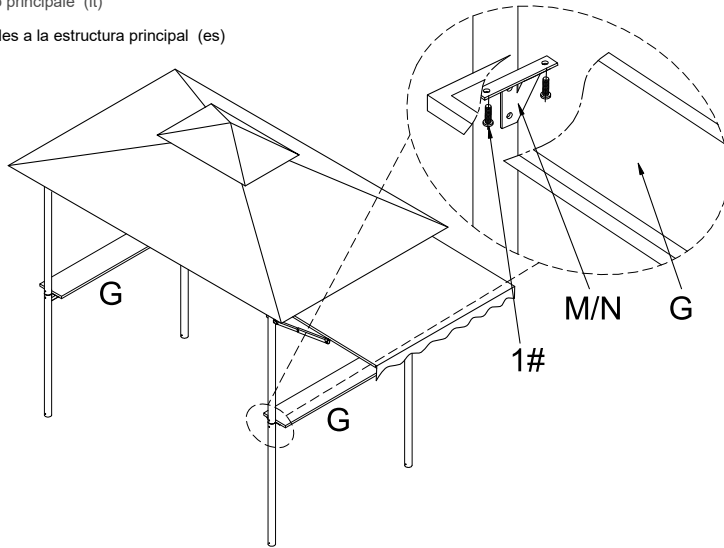

Sichern Sie die Bodenhaftung des Pavillongestells mittels der mitgelieferten Bodenpfähle.

Achtung: Die Bodenpfähle eignen sich nur für Rasenflächen. Wenn Sie den Pavillon auf Decks oder harten Oberflächen befestigen wollen, müssen Sie für eine geeignete Befestigung sorgen. (de)

Use provided ground stakes for lawns ,if securing to decks or hard surfaces ,use appropriate hardware(SOLID SEPARATELY) (en)

Utilisez les enjeux de terrain pour les pelouses, si vous vous trouvez sur des ponts ou des surfaces dures, utilisez un matériel approprié (SOLIDE SEPAREMENT) (fr)

Utilizzare i pali a terra forniti per i prati, se fissati a ponti o superfici dure, utilizzare un'attrezzo appropriato (it)

Utilice las estacas o picas de tierra proporcionadas para el césped. Si se coloca sobre cubiertas o superficies duras, utilice el equipo o materiales apropiados (SÓLIDO SEPARADAMENTE). (es)

**(de)**

Produktparameter:

Größe: 235×145×245cm

Gewicht: ca. 23kg

Material:

Baldachin: Polyester

Pavillon Gestell: Stahl

**(en)**

Product parameters

size: 235×145×245cm

Weight:about 23kg

Material:

canopy:polyster

gazeboframe:steel

**12**

Befestigen Sie den Haken an den Regalen / Feste Bodenpfähle (de)

Attach the hook to the shelves / Fixed ground stakes (en)

Fixez le crochet aux étagères / Fixe Enjeux pour le terrain (fr)

Attaccare il gancio agli scaffali / Puntì a terra fissi (it)

Acople el gancho a los estantes / Estacas de tierra fijas (es)

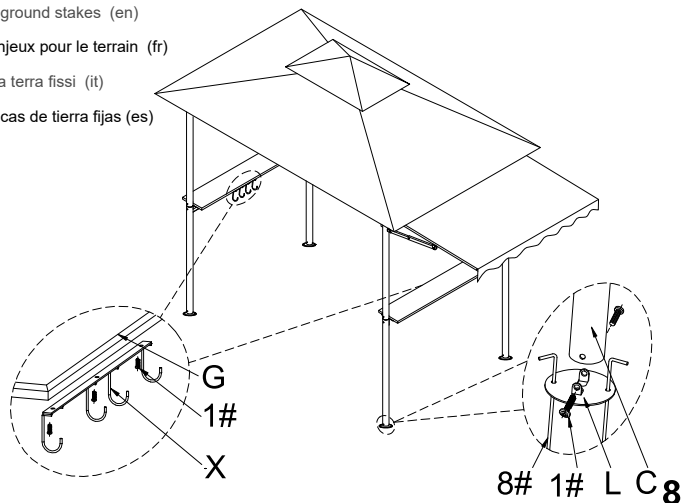
**(fr)**

Paramètres du produit

Taille: 235×145×245cm

Poids: environ 23kg

Matériel:

canopée : polyester

support de pavillon: acier

**(it)**

Dimensione dei parametric

del prodotto: 235×145×245cm

Peso: circa 23kg

Materiale:

copertura: poliester

telaio gazebo: acciaio

**(es)**

Parámetros del producto

Tamaño: 235×145×245cm

Peso: Aprox. 23kg

Materiales:

Toldo: Poliéster

Estructura del Gazebo: Acero